

Schematics - Main PWB

Baseband - Top Level

Version 0.0, edit 164

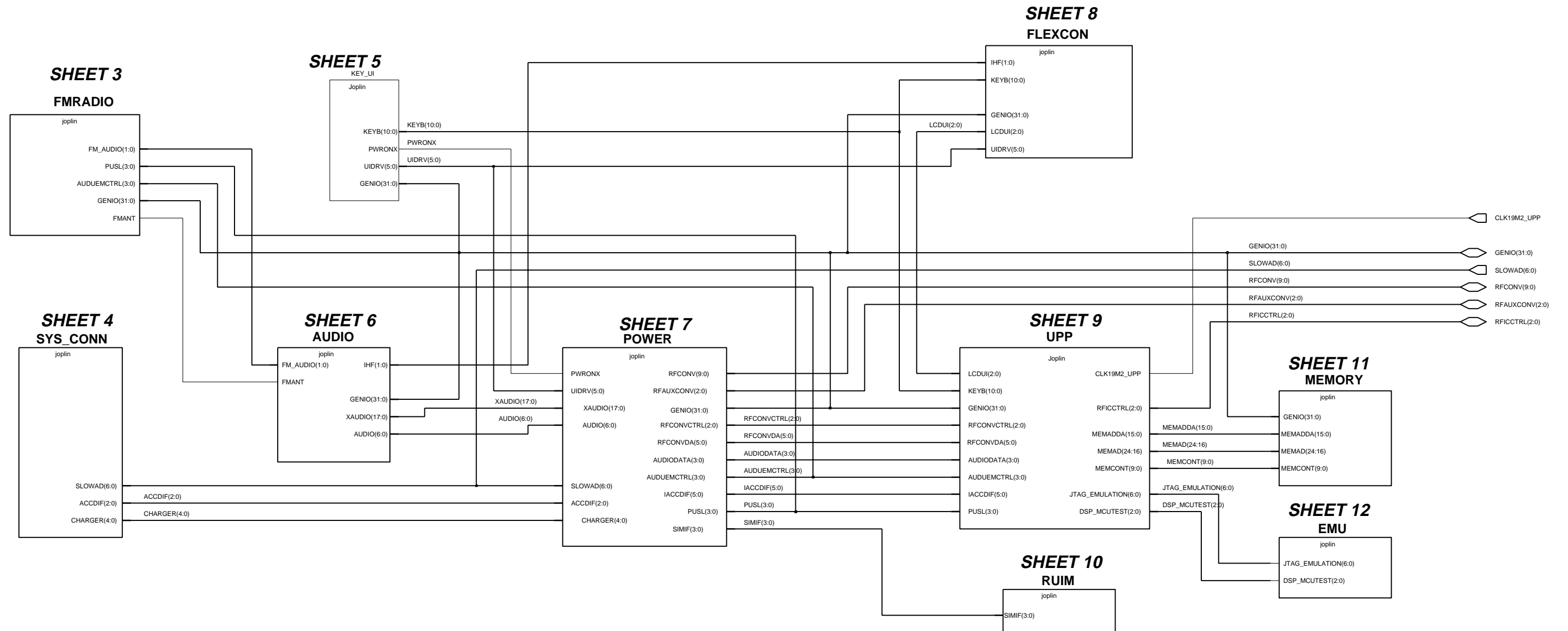

Front End

Version 0.0, edit 136

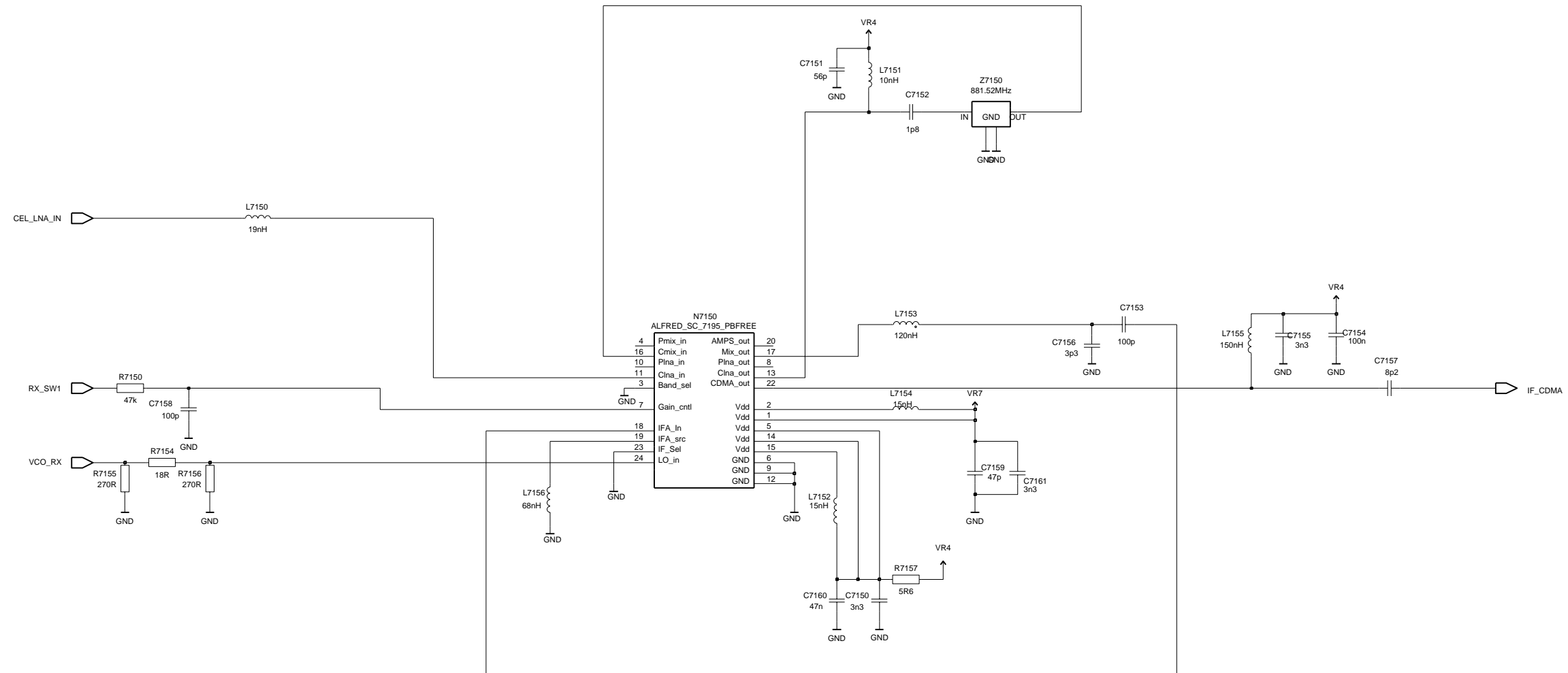

Audio

Version 0.0, edit 201

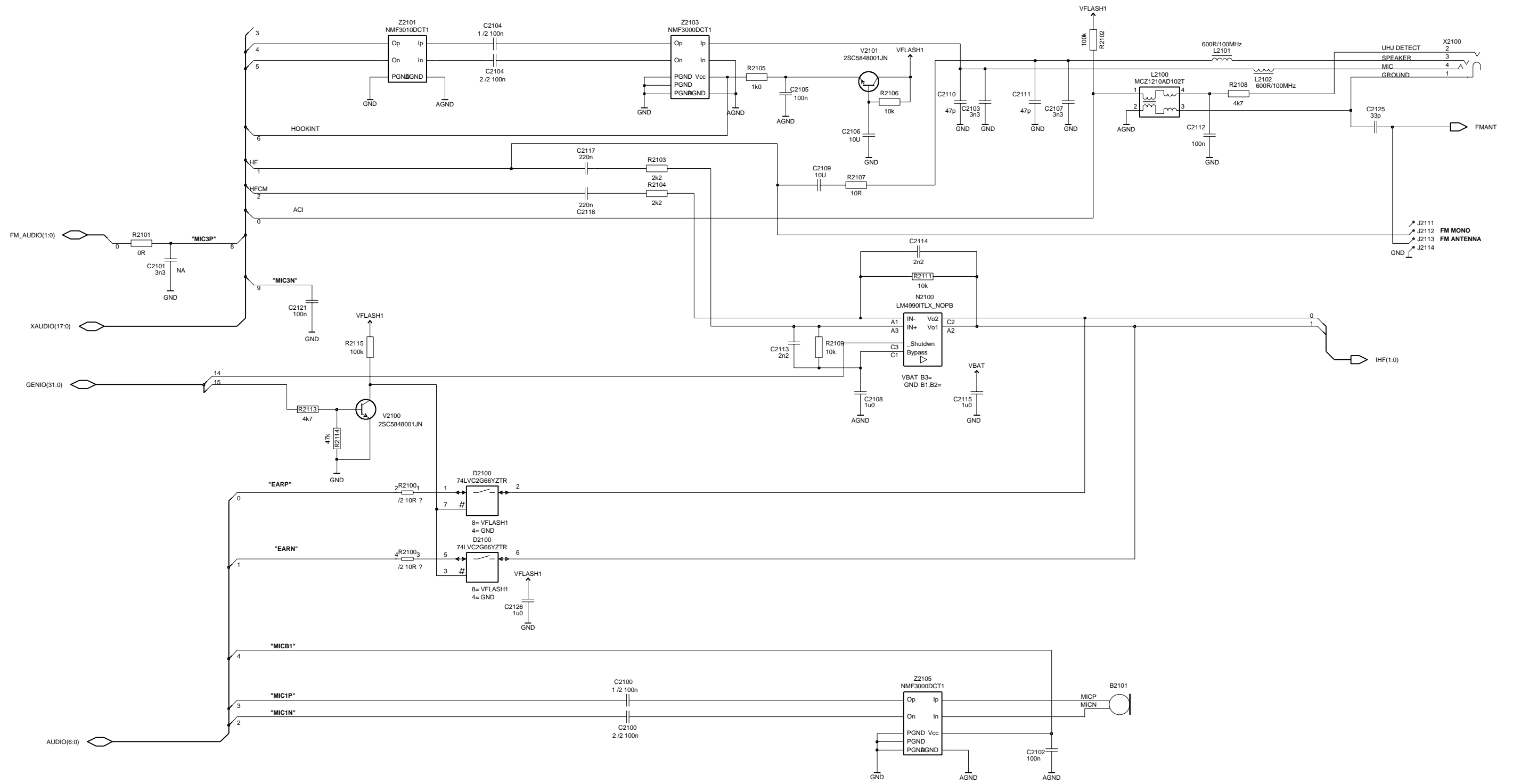

**NA=NOT ASSEMBLED**

Rx

Version 0.0, edit 137

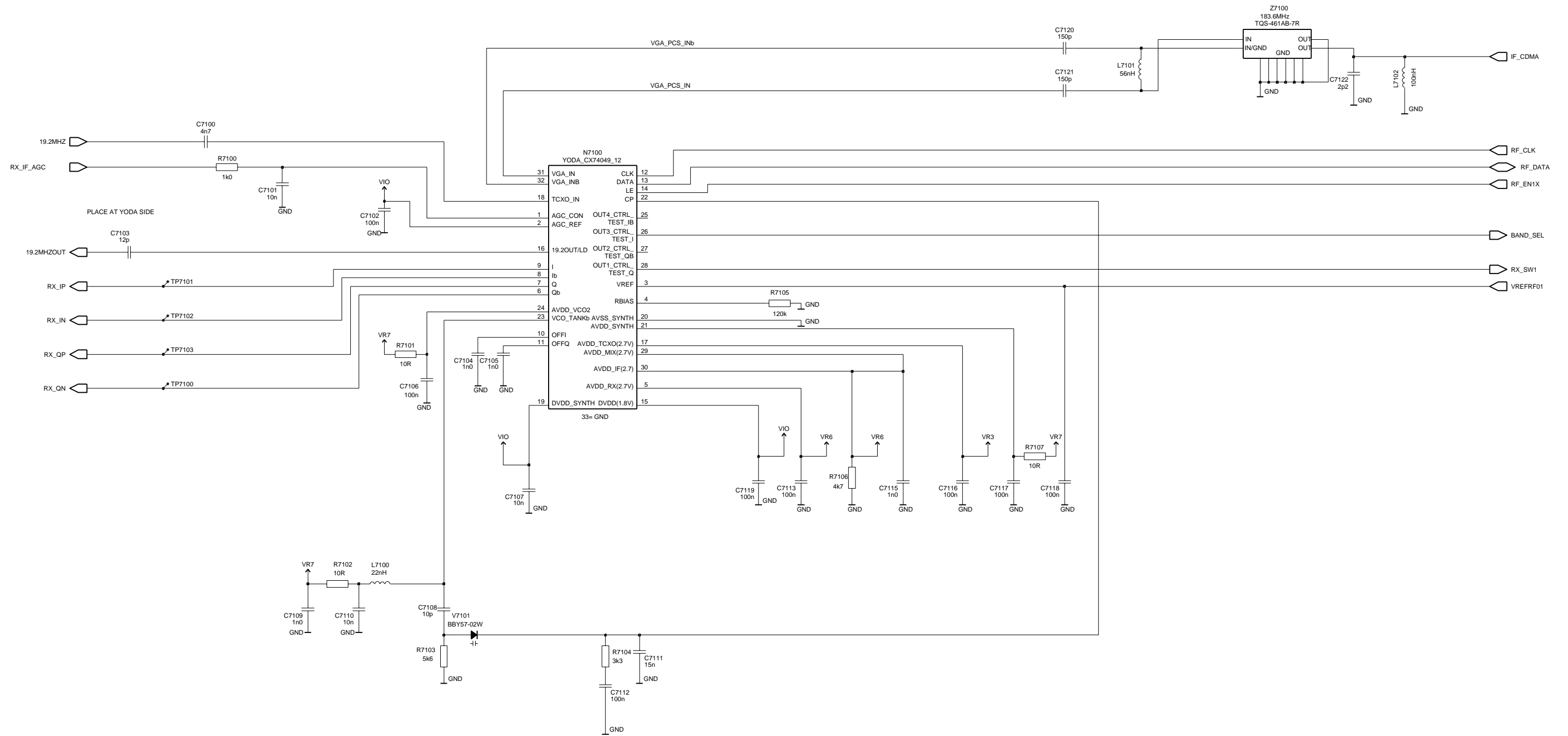

Key UI

Version 0.0, edit 184

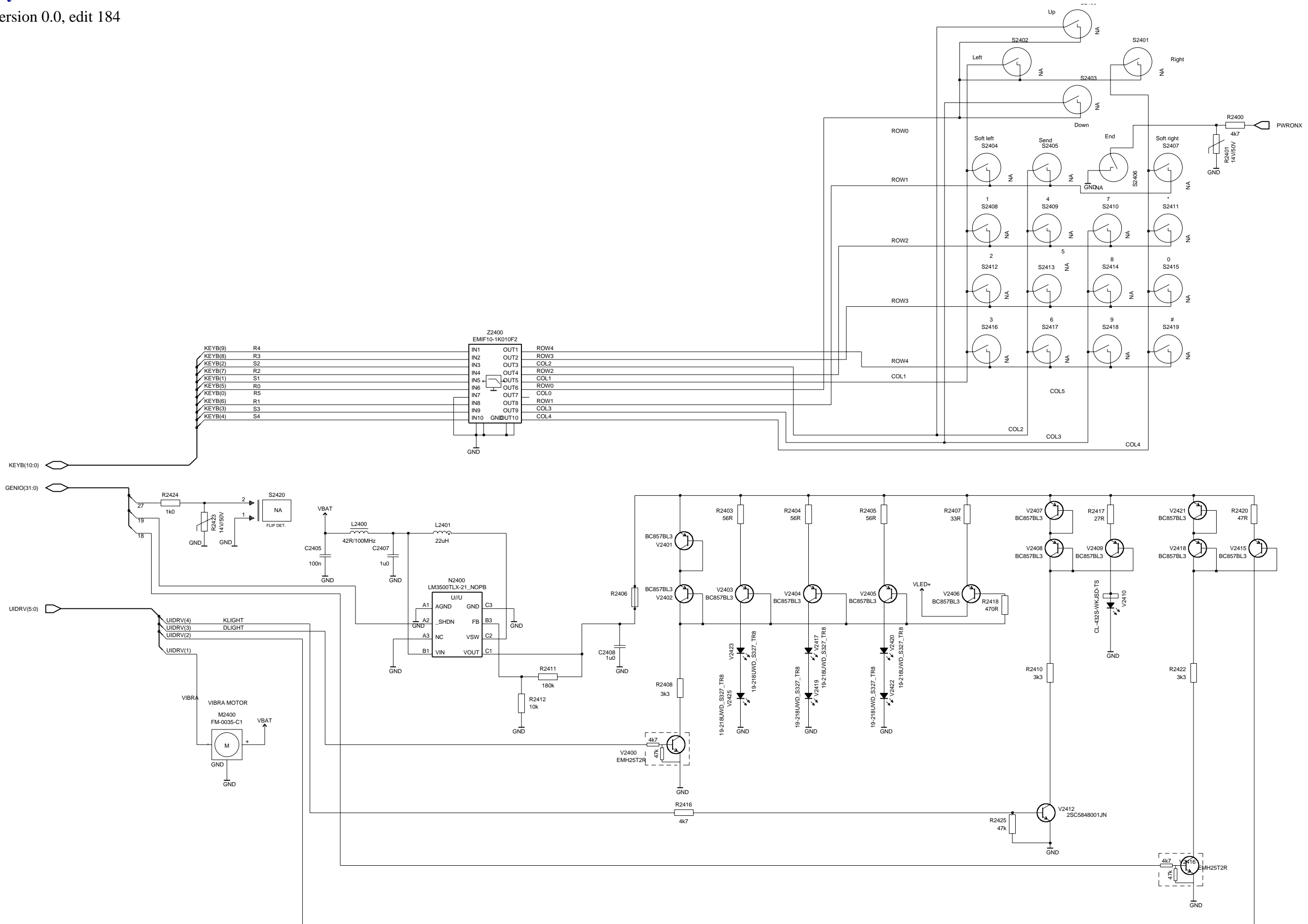

Memory

Version 0.0, edit 144

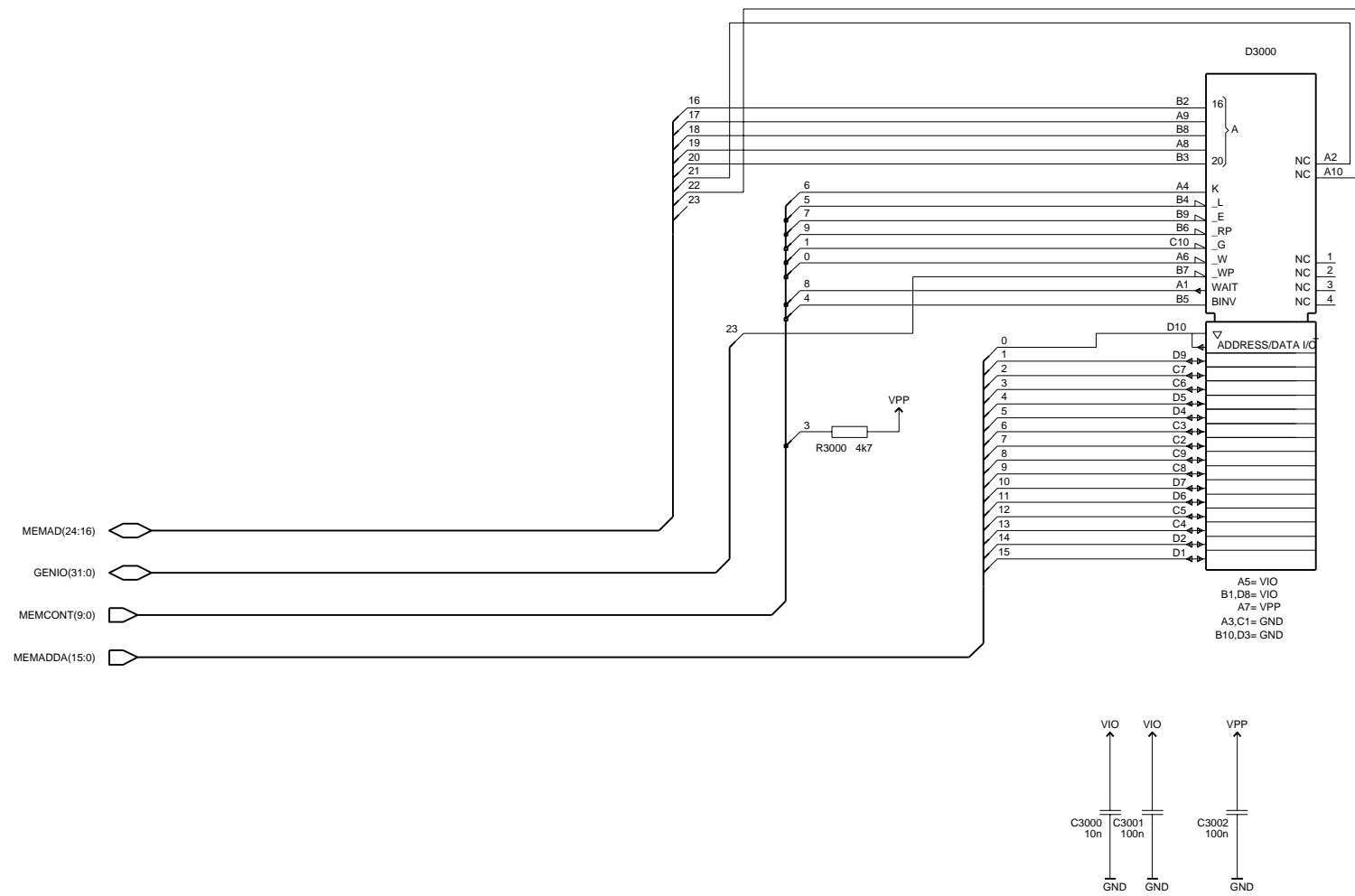

PA

Version 0.0, edit 149

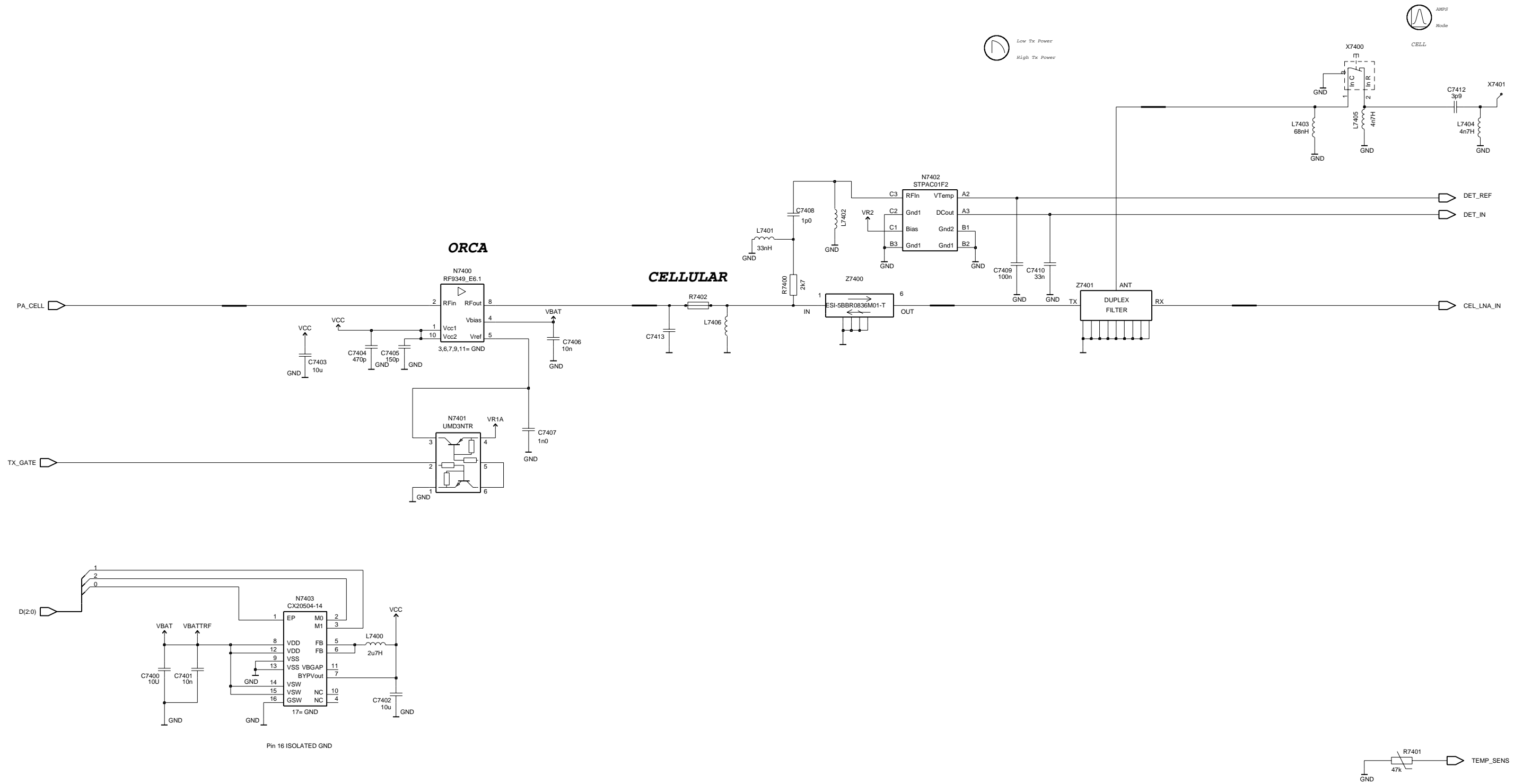

**RF-BB Interface**

Version 0.5, edit 150

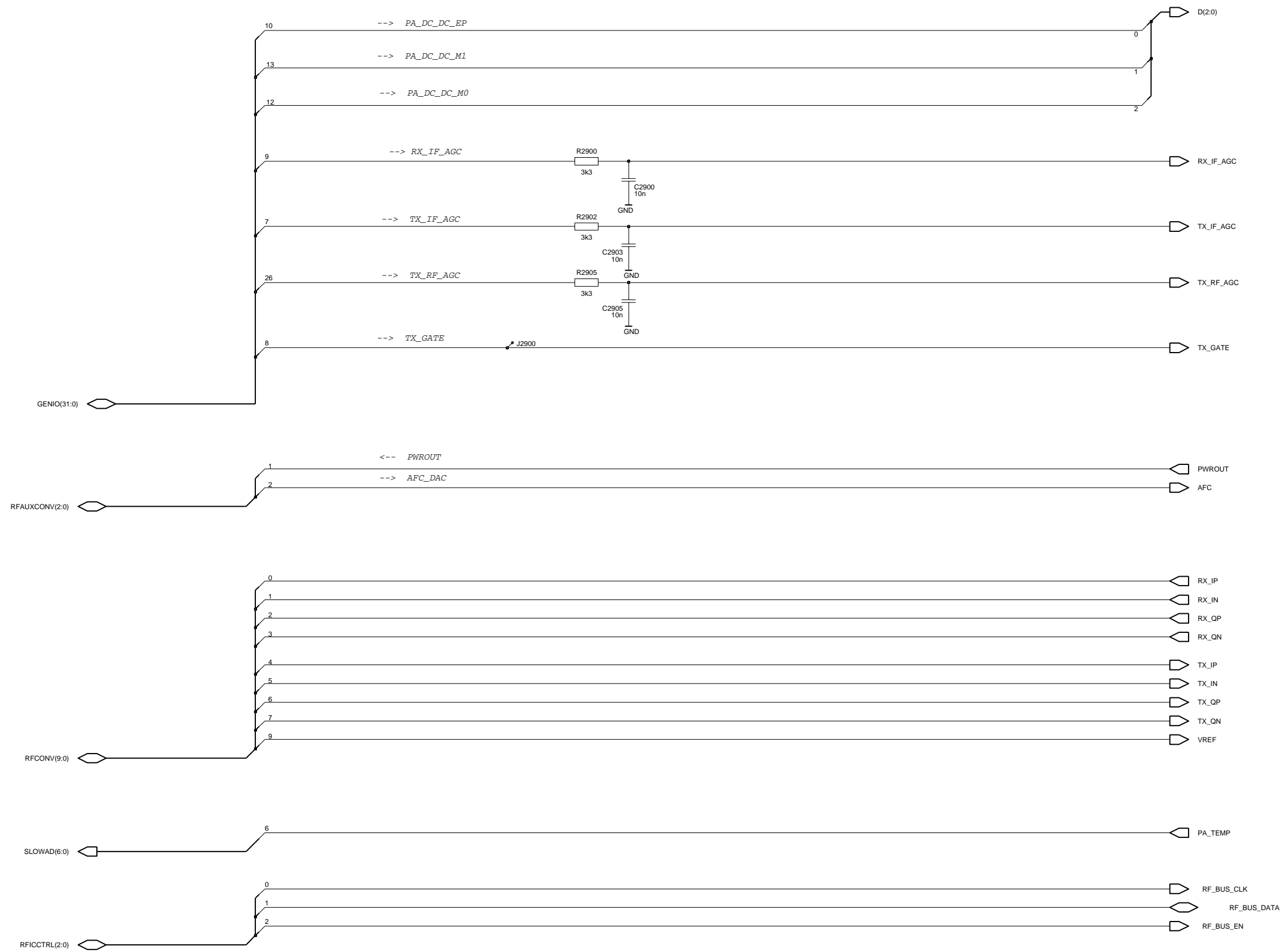



RF - Top

Version 0.0, edit 126

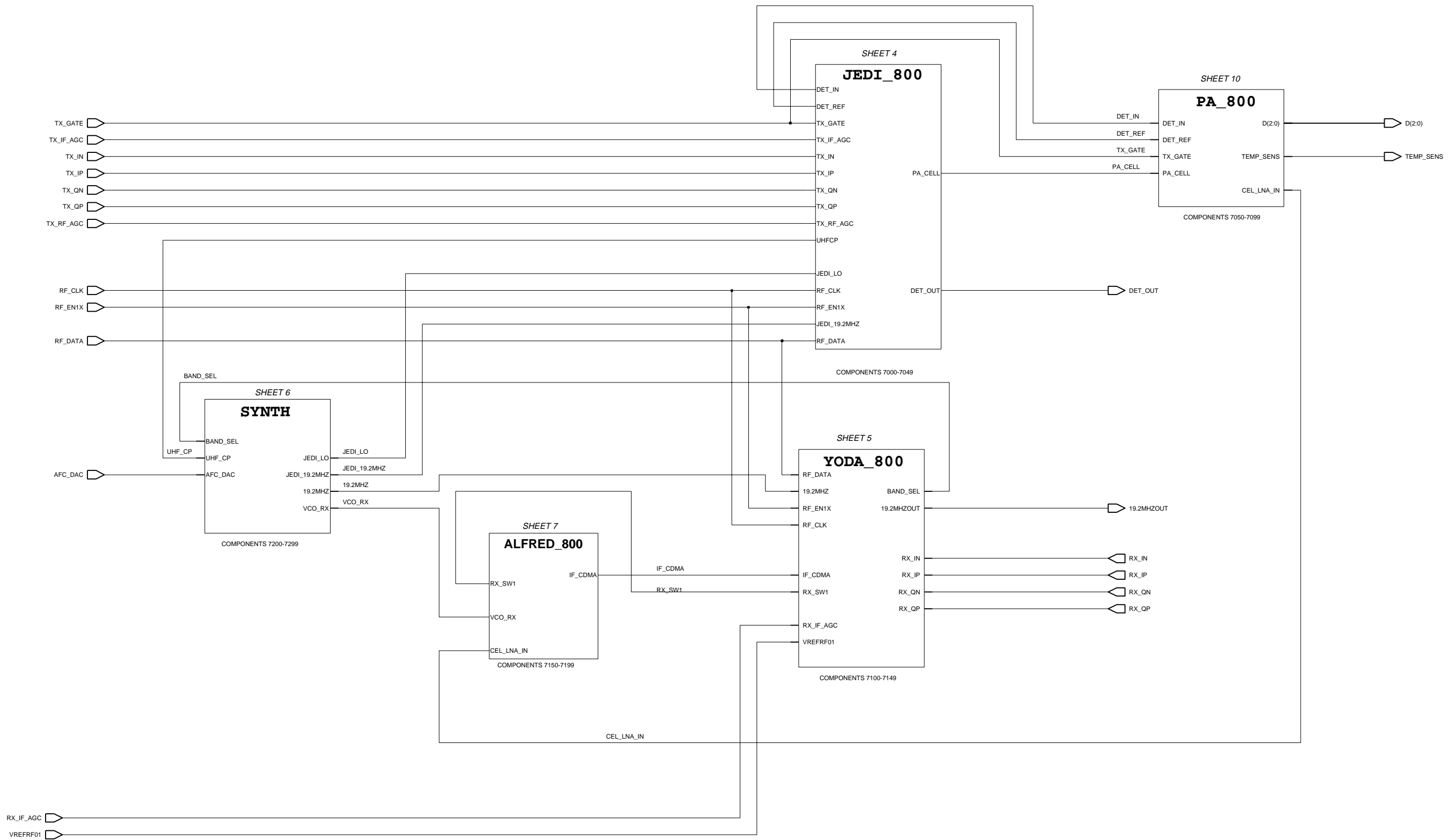

UIM Card Connector

Version 0.0, edit 143

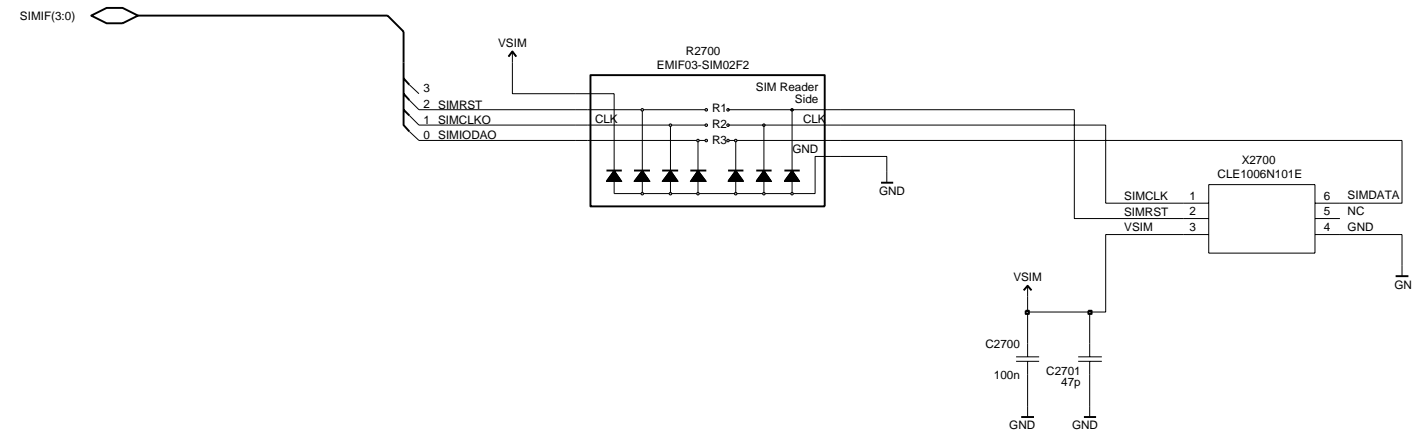

**NOT POPULATED FOR 0202849 NON-RUIM**

**System Connector**

Version 0.0, edit 172

**BATTERY CONNECTOR**



**DCT3 CHARGER CONNECTOR**

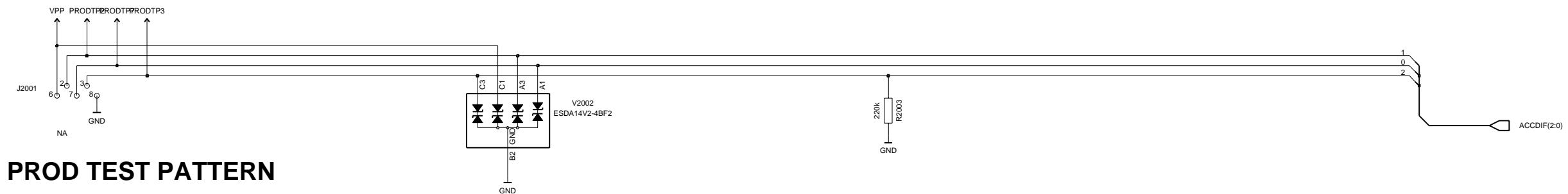
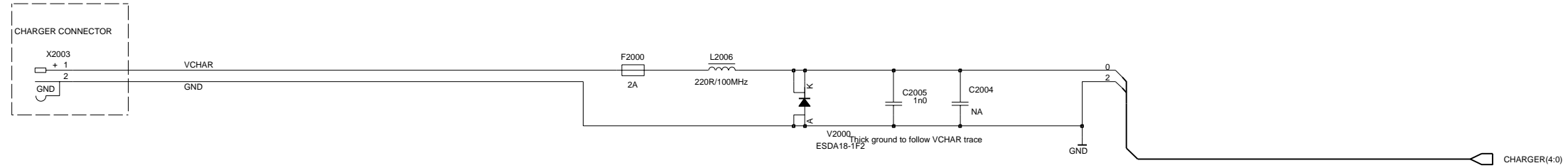

**PROD TEST PATTERN**

**NA=NOT ASSEMBLED**

Synthesizer

Version 0.0, edit 125

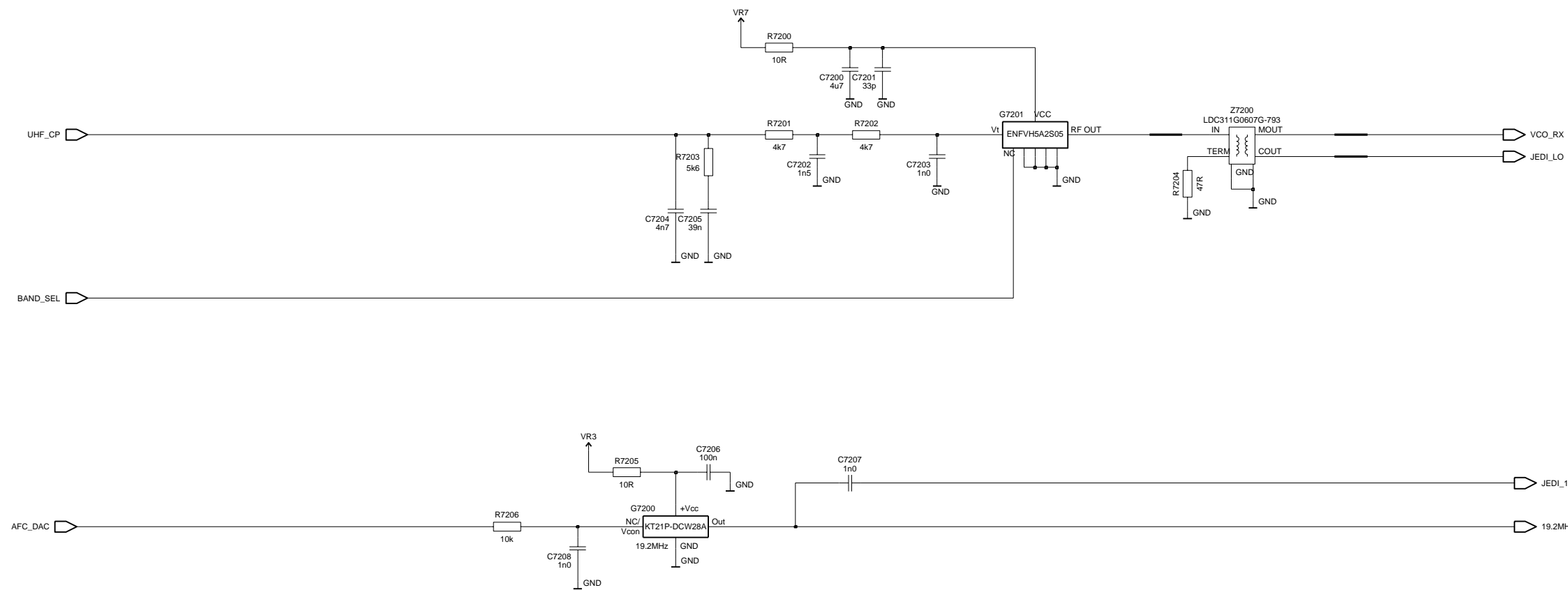

Top Level

Version 0.0, edit 172

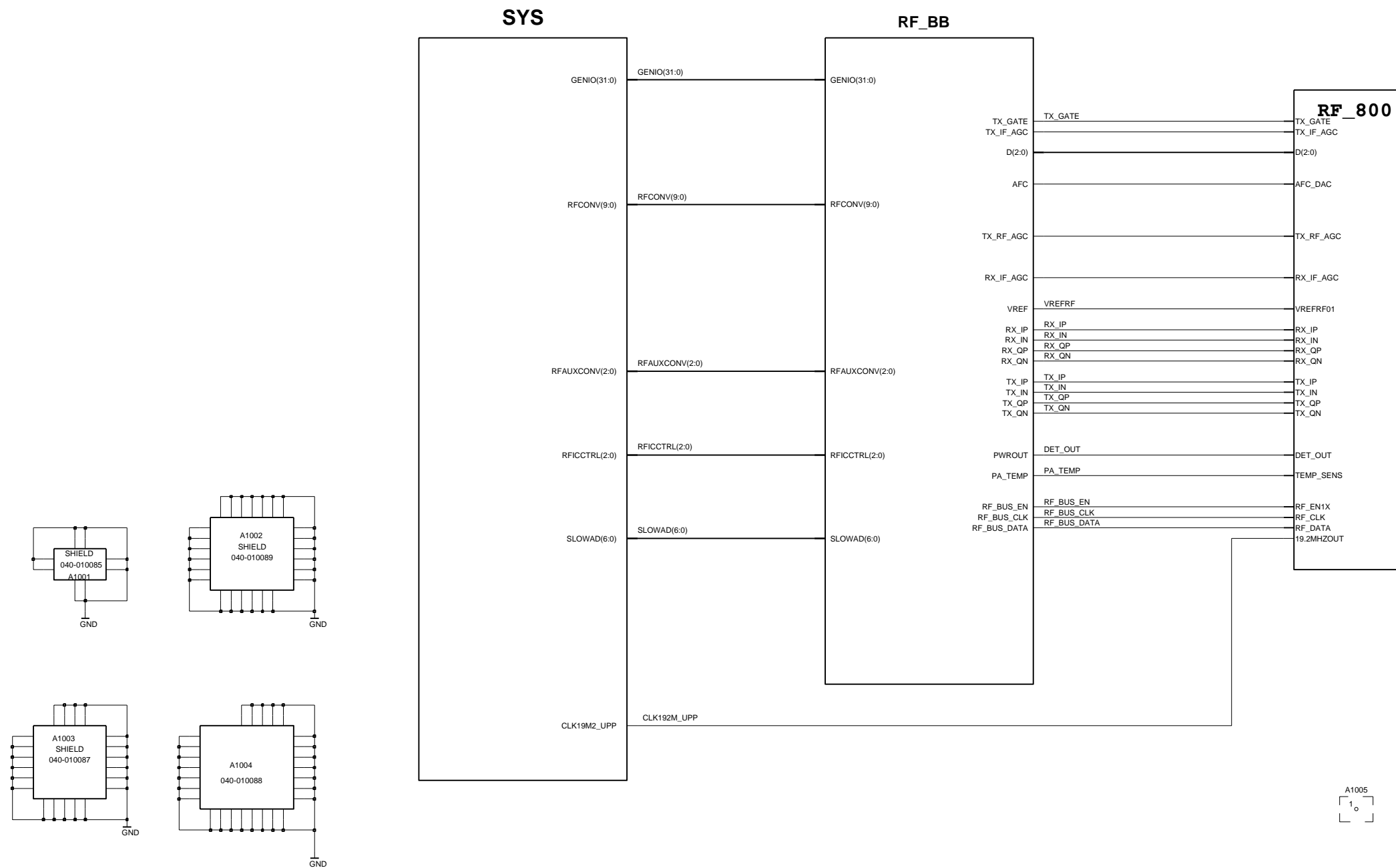

UEME

Version 0.0, edit 161

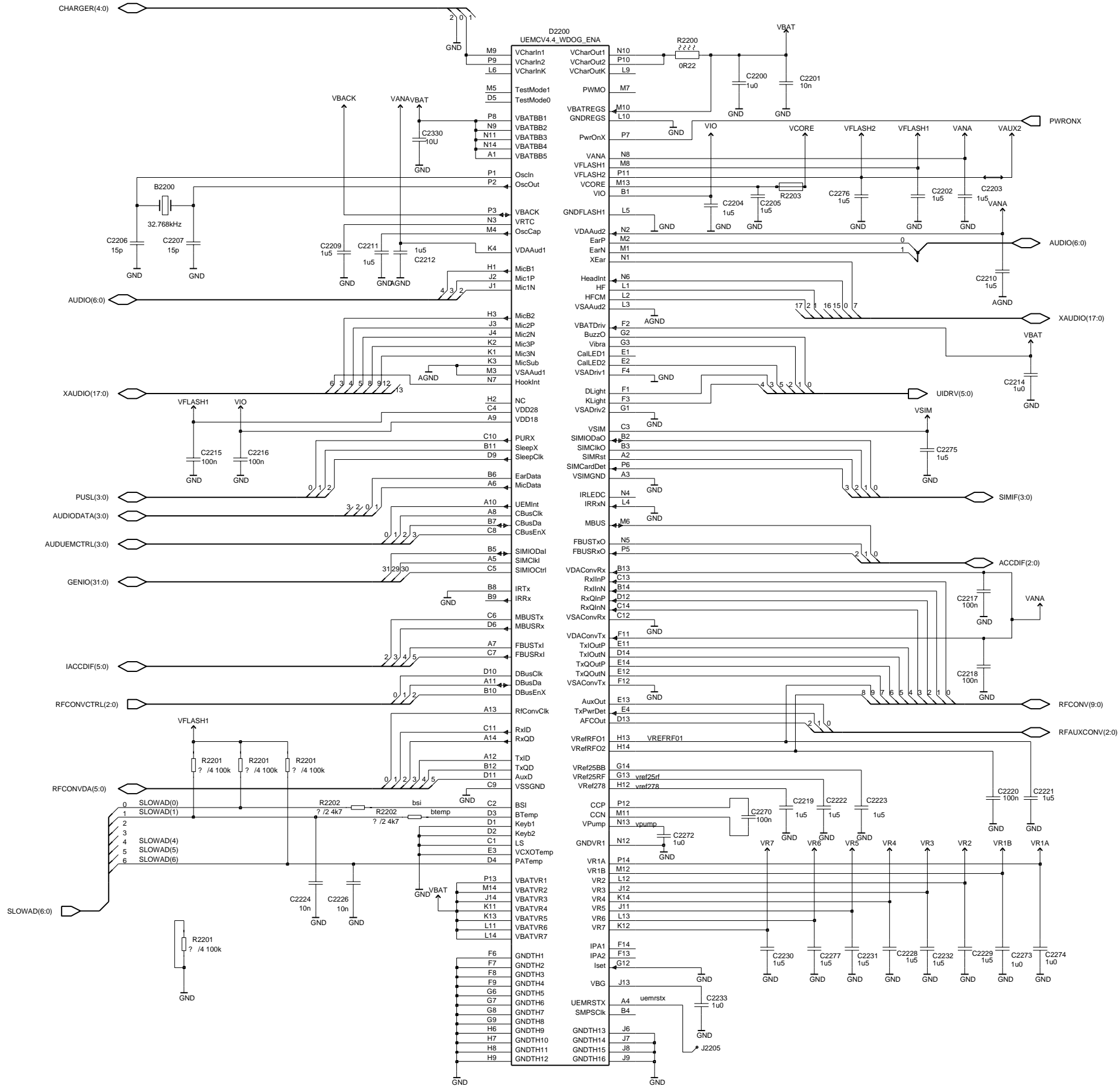

UPP

Version 0.0, edit 141

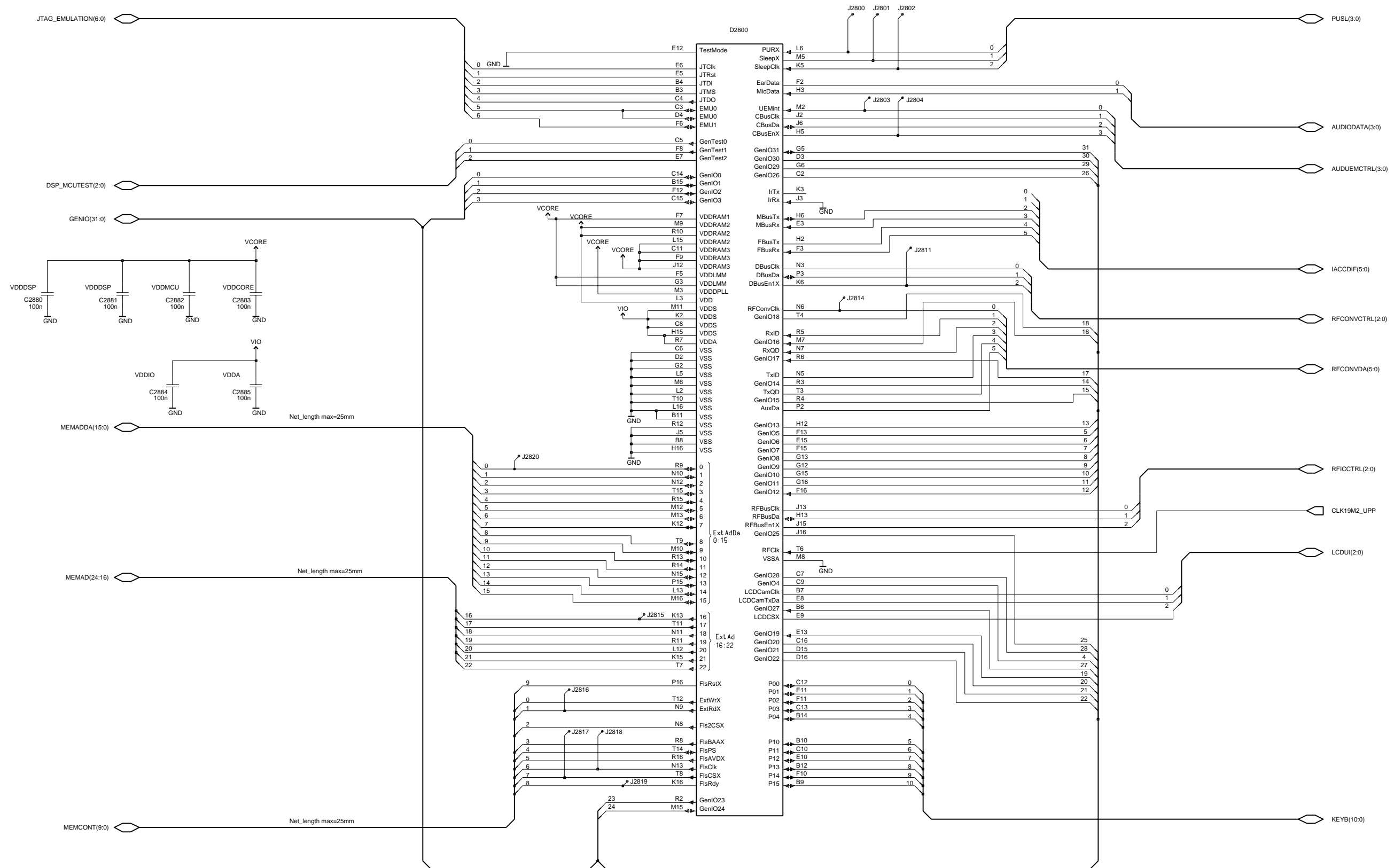

Tx

Version 0.0, edit 133

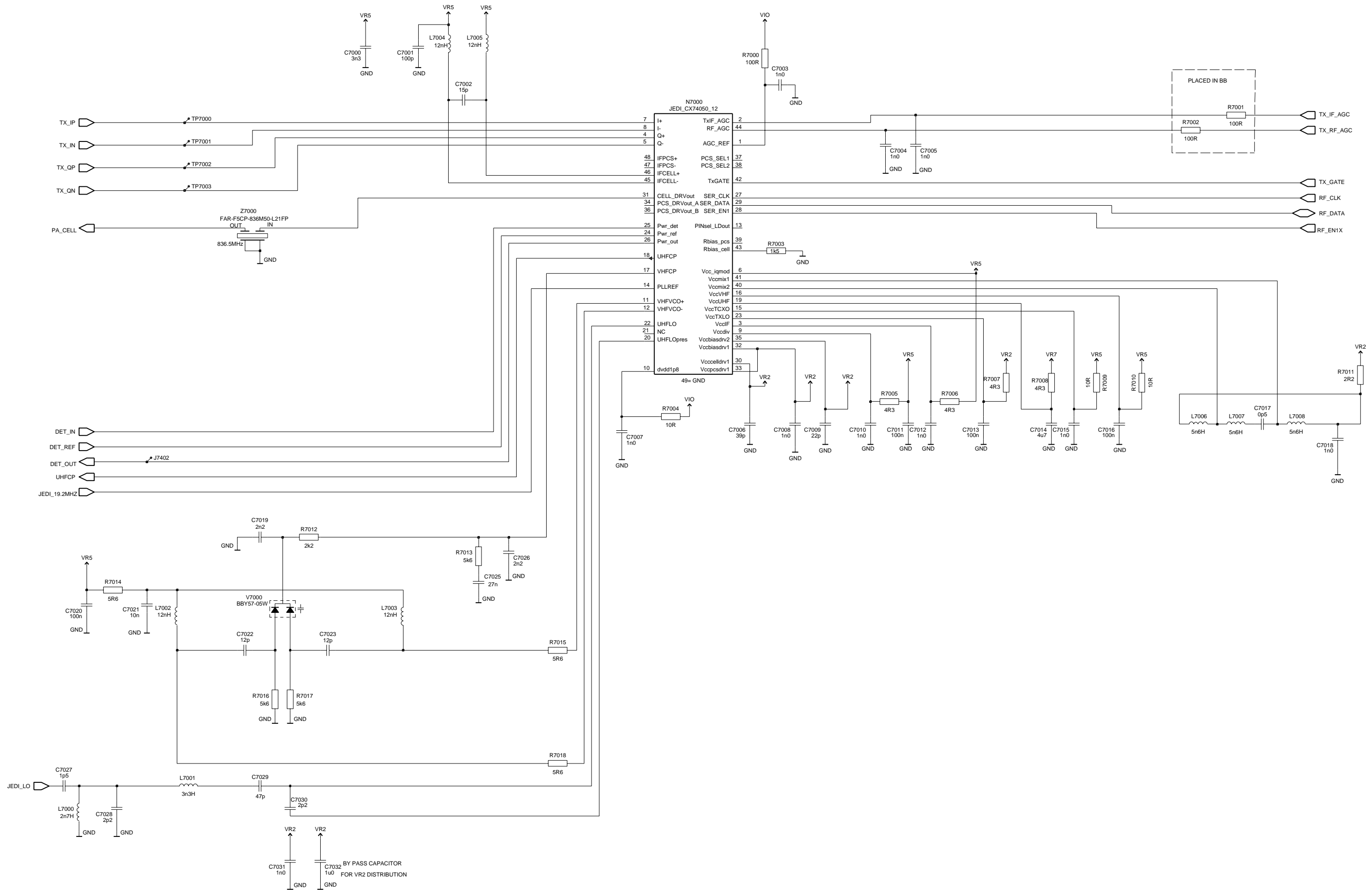



FM Radio

Version 1.3, edit 150

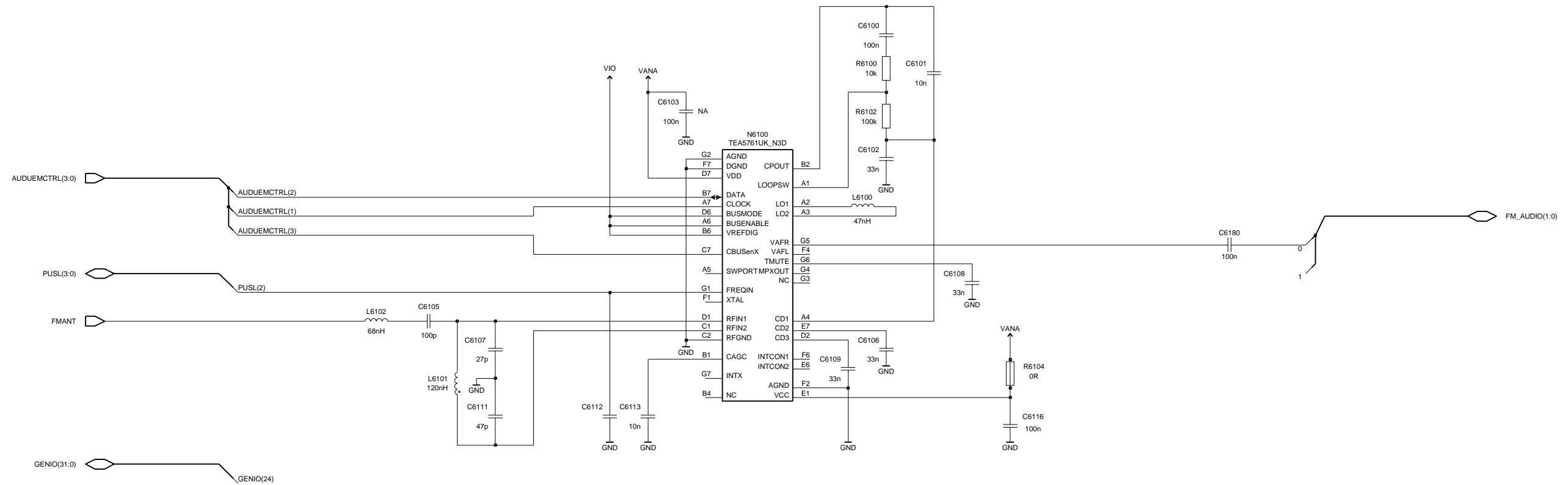

Flex Connector

Version 0.0, edit 167

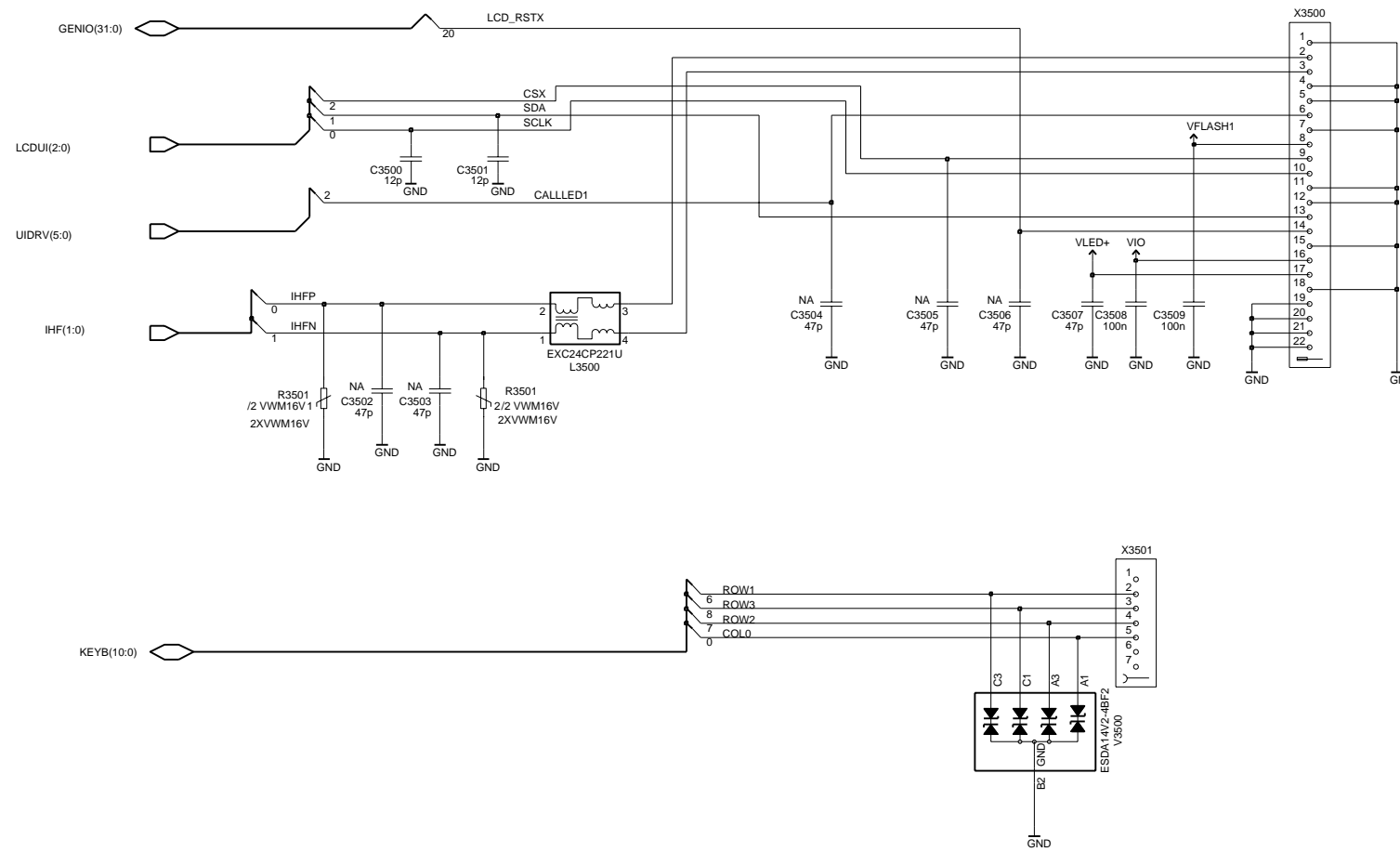

**NA=NOT ASSEMBLED**

2255 Component Layout - Top

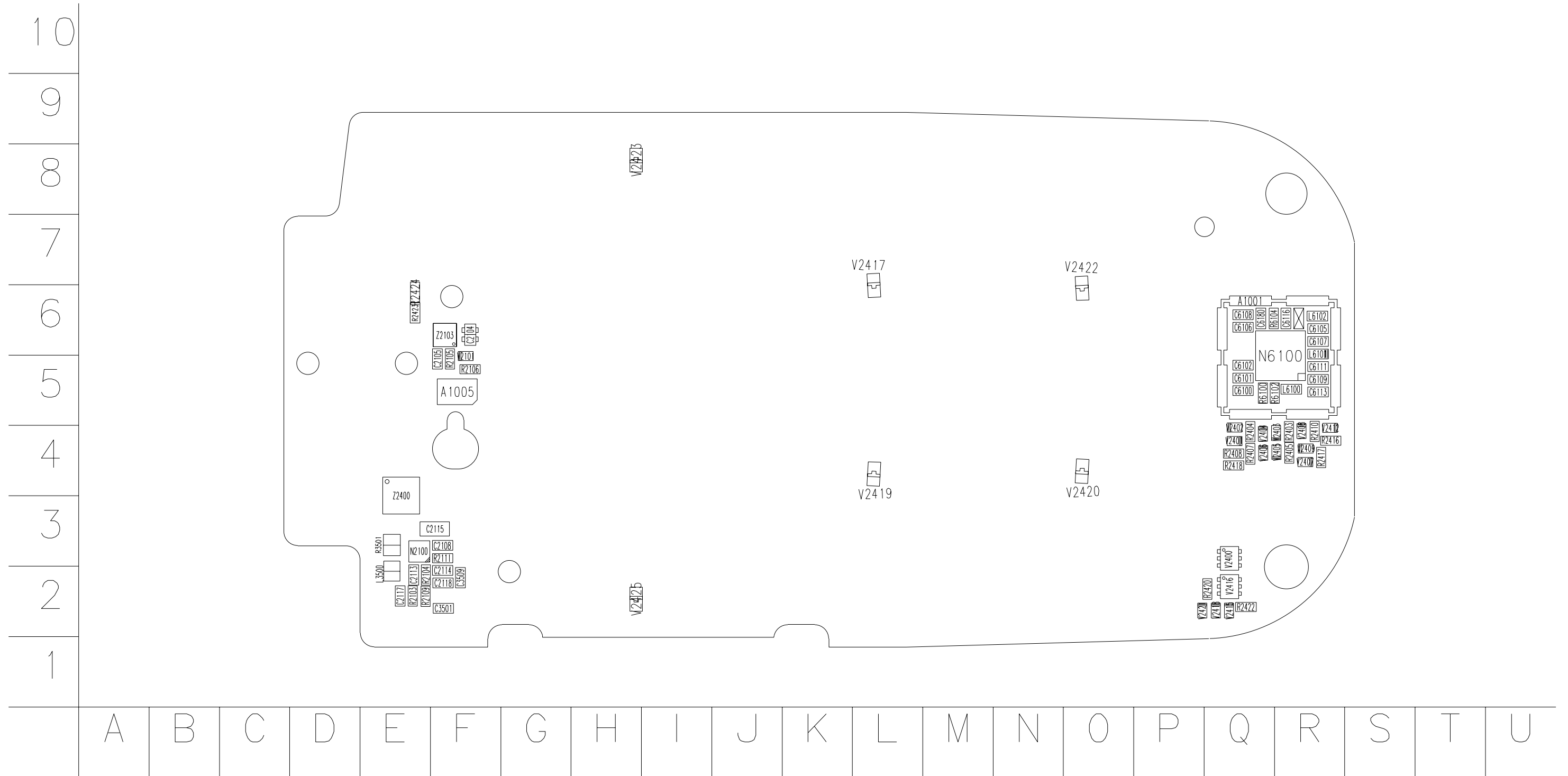

2255 Component Layout - Bottom

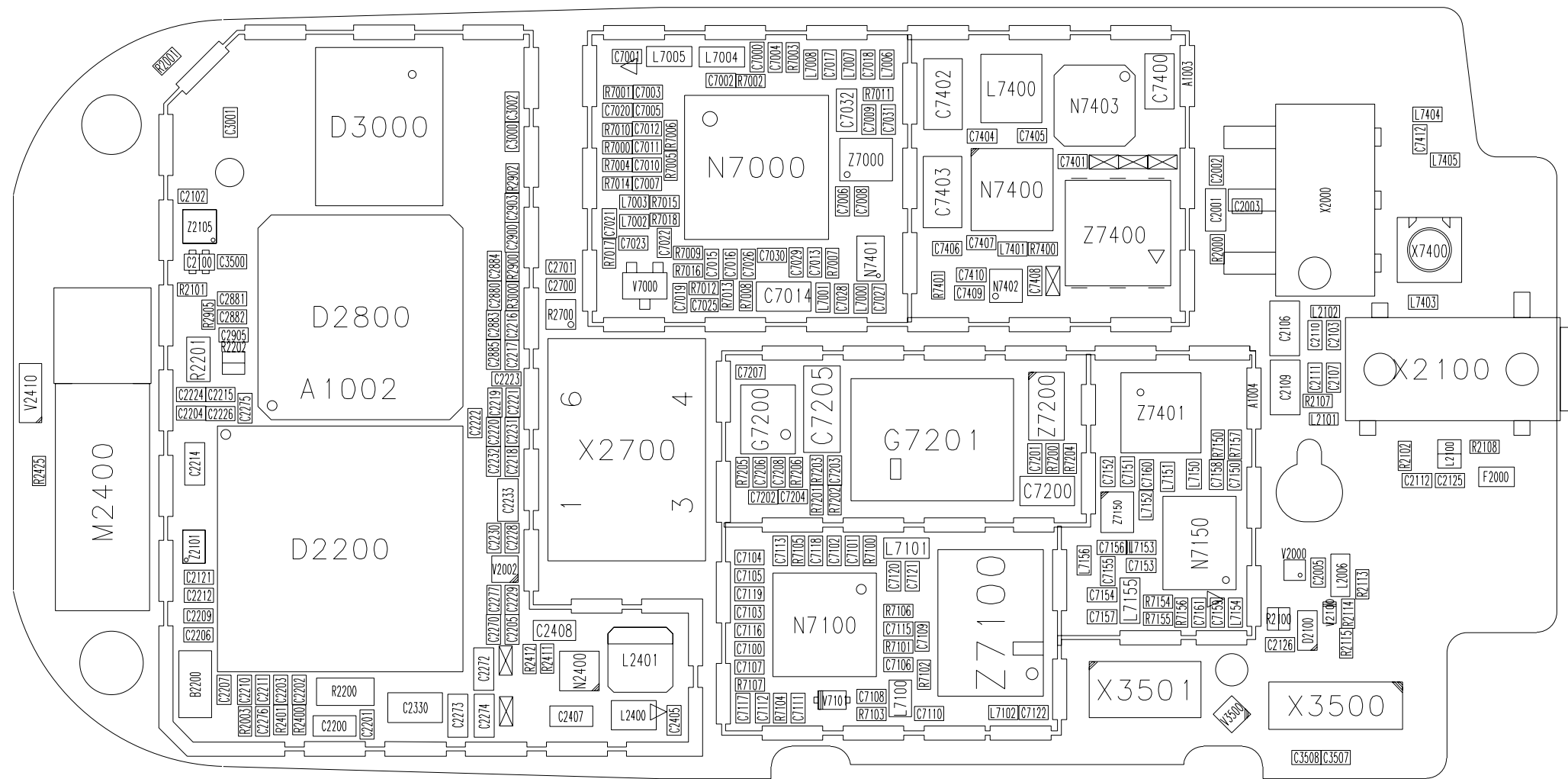

10
9
8
7
6
5
4
3
2
1

U	T	S	R	Q	P	O	N	M	L	K	J	I	H	G	F	E	D	C	B	A
---	---	---	---	---	---	---	---	---	---	---	---	---	---	---	---	---	---	---	---	---